



<http://support.kesseboehmer.de/15er>

Montageanleitung

Handtuchhalterauszug
Backblech- und Tablettauszug

Mounting Instructions

Towelholder pull-out
Tray and baking tray pull-out

Kesseböhmer XP

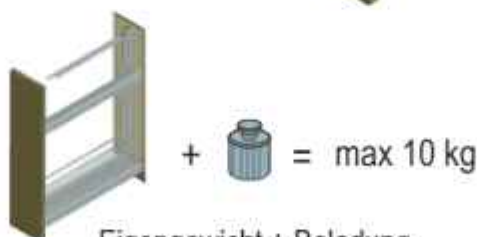
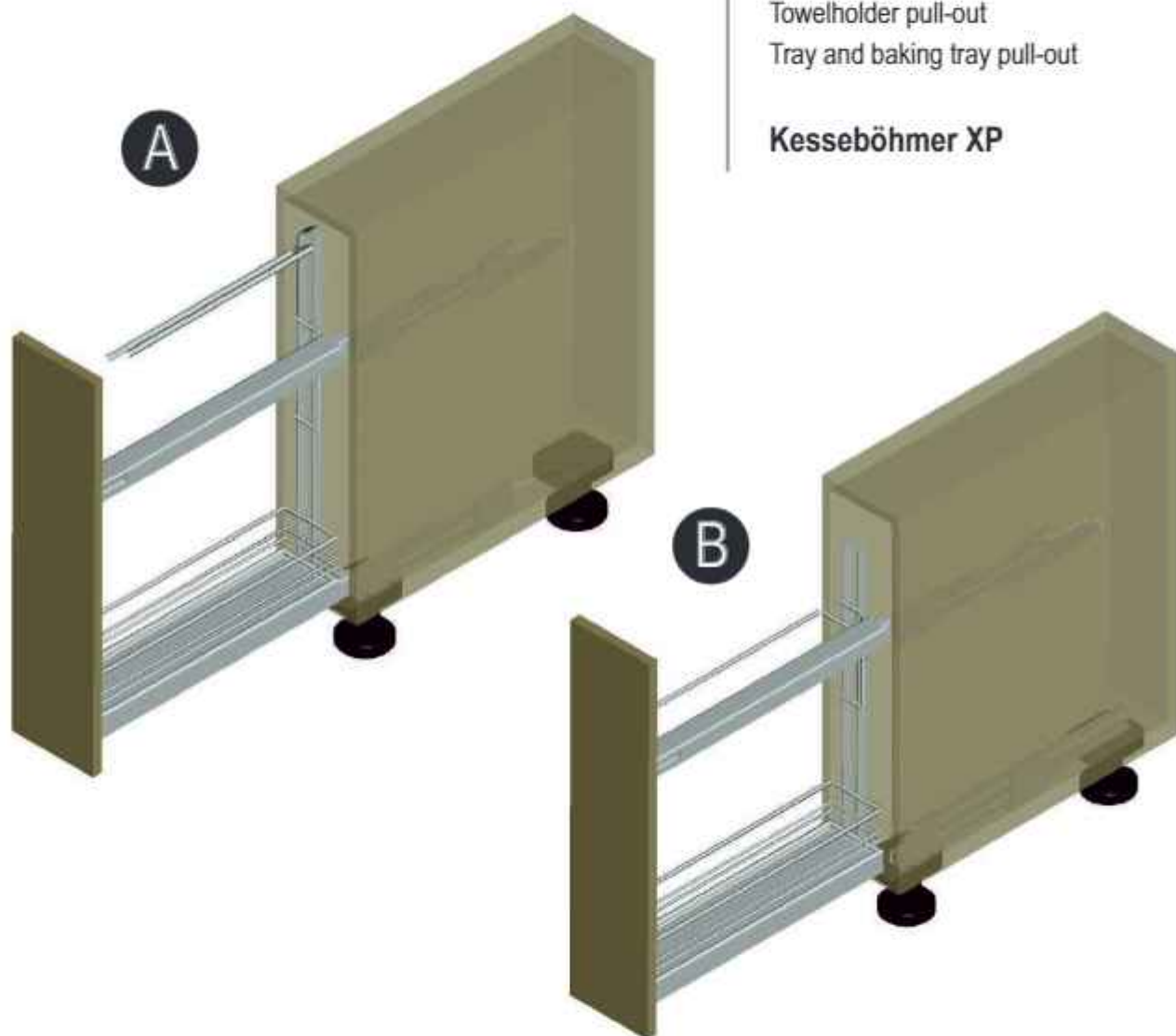

Eigengewicht + Beladung
Empty weight + Load





SYMBOLE • SYMBOLS • SYMBOLES • SIMBOLI • SÍMBOLOS • SÍMBOLOS • MERKIT • SYMBOLER • SYMBOLY • SYMBOLE



Warnung! • Warning! • Avertissement! • Avvertenza! • Advertencia! • Aviso! • Varoitus! • Advarsel! • Výstraha! • Ostrzeżenie!



Nicht korrekt! • Incorrect! • Incorrect! • Non corretto! • ¡Incorrecto! • Incorrecto! • Väärin! • Ikke korrekt! • Nesprávne! • Nieprawidłowo!



Korrekt! • Correct! • Correct! • corretto! • ¡Correcto! • Correcto! • Oikein! • Korrekt! • Správne! • Prawidłowo!



Fixieren/fixiert! • Secure/Secured! • Fixer/fixé • Fissare/fissato! • ¡Fijar/fijado! • Fixar/fixo! • Kiinnitä/kiinnitetty! • Spænde/spændt • Upevniť/upevněno! • Zamocować/zamocowane!



Lösen/gelöst! • Release/Released! • Détacher/détaché • Allentare/allentato! • ¡Soltar/suelto! • Soltar/solto! • Irroita/irroitettu! • Løsne/løsnet • Povolit/povoleno! • Zwolnić/zwolnione!



Keinen Akkuschauber verwenden! • Do not use a cordless screwdriver! • Ne pas utiliser de tournevis à piles • Non utilizzare un avvitatore a batteria! • ¡No utilizar taladro atomillador! • Não usar aparafusadora sem fio! • Älä käytä akkuuuviväännintä! • Brug ikke batteriskruetrækker! • Nepoužívejte akušroubovák! • Nie używać wkrętarki akumulatorowej!



PZ2-Schraubendreher verwenden! • Use a PZ2 screwdriver! • Utiliser un tournevis PZ2 • Usare il cacciavite PZ2! • ¡Utilizar un destornillador PZ2! • Usar chave de parafusos PZ2! • Käytä PZ2-ruuvitaltta! • Brug PZ2-skrueetrækker! • Použijte křížový šroubovák PZ2! • Użyć wkrętaka PZ2!



Optionales Element! • Optional element! • Élément optionnel • Elemento opzionale! • ¡Elemento opcional! • Elemento opcional! • Valinnainen elementti! • Valgfrit element! • Volitelný prvek! • Element opcjonalny!



Klick-Geräusch beim Einrasten! • Audible click on engagement! • « Clic » lors de l'encliquetage • Quando si innesta si sente un clic! • ¡Cuando encaja se oye un clic! • Ruido de clique ao engatar! • Lukittuessa kuuluu klik-äänit! • Kliklyd ved montering! • Slyšitelné zacvaknutí! • Trzask przy zaskakiwaniu!



Alle Maße in mm! • All dimensions in mm! • Toutes les dimensions en mm! • Tutte le dimensioni in mm! • ¡Todas las medidas son en mm! • Todas as medidas em mm! • Kaikki mitat mm! • Alle mål er mm! • Všechny rozměry v mm! • Wszystkie wymiary w mm!

Ausziehsicherung vorhanden! • Pull-out stop available! • Présence d'une protection anti-sortie! • Sicura di estrazione presente! • ¡Tope de seguridad integrado! • Protecção contra extracção disponível! • Varusteena ulosvetopysäytin • Med udtræksstop! • Nainstalovaná pojistka proti vytažení! • Zamontowano zabezpieczenie przed wyciągnięciem!

Korrosionsprüfung nach DIN EN ISO 6270-2 • Corrosion test according to DIN EN ISO 6270-2 • Contrôle de la corrosion selon DIN EN ISO 6270-2 • Prova di corrosione secondo la norma DIN EN ISO 6270-2 • Prueba de corrosión según DIN EN ISO 6270-2 • Ensaio de corrosão conforme DIN EN ISO 6270-2 • DIN EN ISO 6270-2 muk. korroosiotestaus • Korrosionsprøving iht. DIN EN ISO 6270-2 • Korozní zkouška dle DIN EN ISO 6270-2 • Badanie odporności na korozję wg DIN EN ISO 6270-2

Die technische Darstellung und Maßangaben – auch bei Abbildungen und Zeichnungen – sind unverbindlich. Konstruktionsverbesserungen sind vorbehalten! • Technical information and stated dimensions (including in illustrations and drawings) must not be regarded as binding. Design subject to change without notice (in interest of improvement)! • Les illustrations techniques et les cotes – y compris sur les schémas et les dessins – sont non contractuelles. Sous réserve d'améliorations de la construction! • Le rappresentazioni tecniche e le indicazioni delle dimensioni – anche nelle figure e nei disegni – non sono vincolanti. Con riserva di miglioramenti di progettazione! • Las descripciones técnicas y los datos dimensionales, inclusive los incluidos en fotos y figuras, son meramente orientativos y no vinculantes. ¡Reservado el derecho a mejoras constructivas! • As descrições técnicas e as indicações de medidas – também em ilustrações e desenhos – não são de natureza imperativa. Salvo melhoramentos de construção! • Tekniset piirrokset ja mitat – myös kuvissa ja piirroksissa olevat – ovat sitoumuksetta. Oikeus teknisiin parannuksiin pidätetään! • De tekniske fremstillinger og måleangivelser – også i figurer og tegninger – er vejledende. Forbehold for konstruktionsforbedringer! • Technické znázornění a rozměry – i na obrázcích a výkresech – jsou nezávazné. Konstruktivní změny vyhrazeny! • Prezentacje techniczne i dane wymiarowe – także na rysunkach – są niewiążące. Zmiany konstrukcyjne zastrzeżone!

No.15 3D-X



KESSEBÖHMER

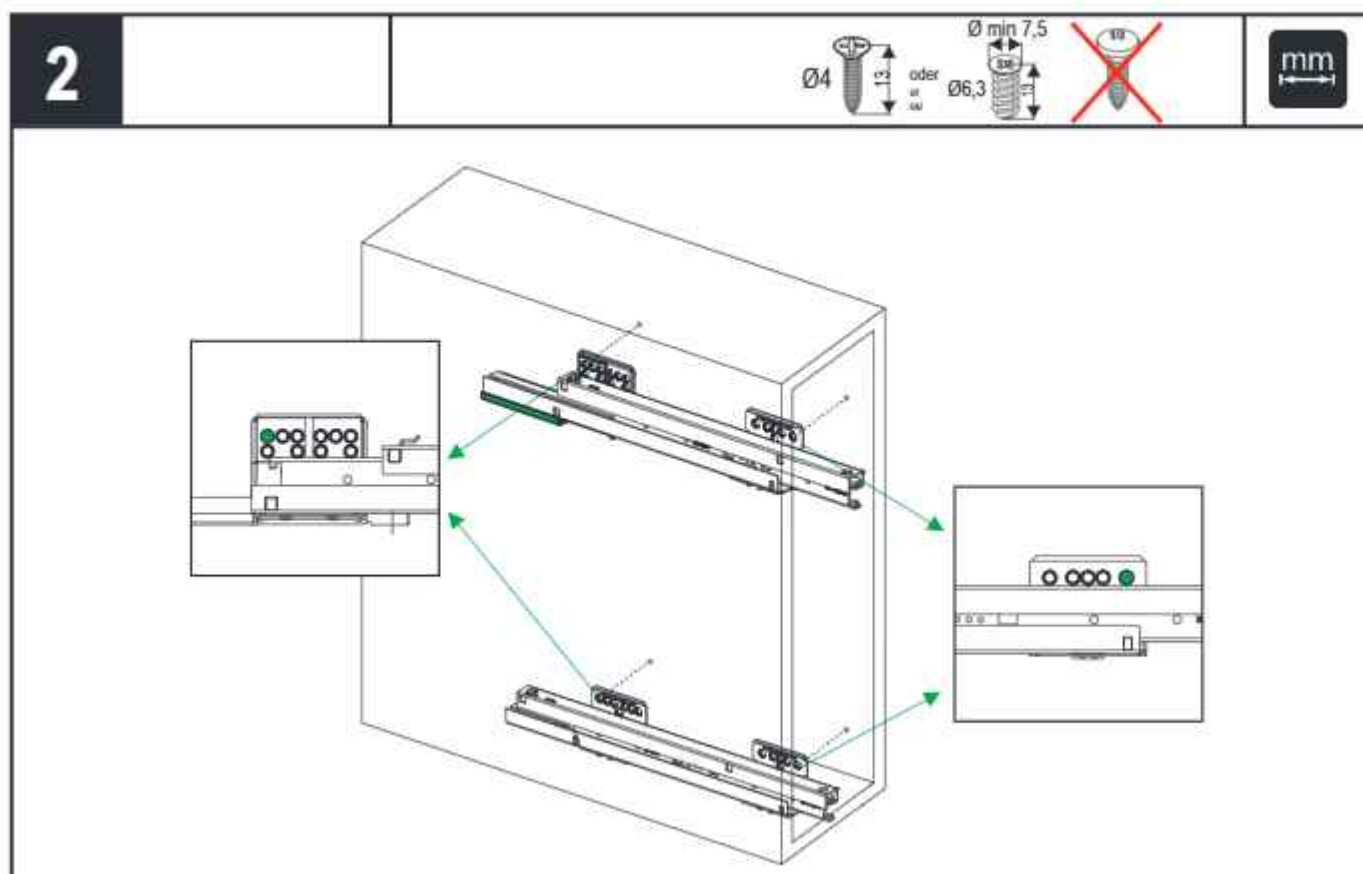
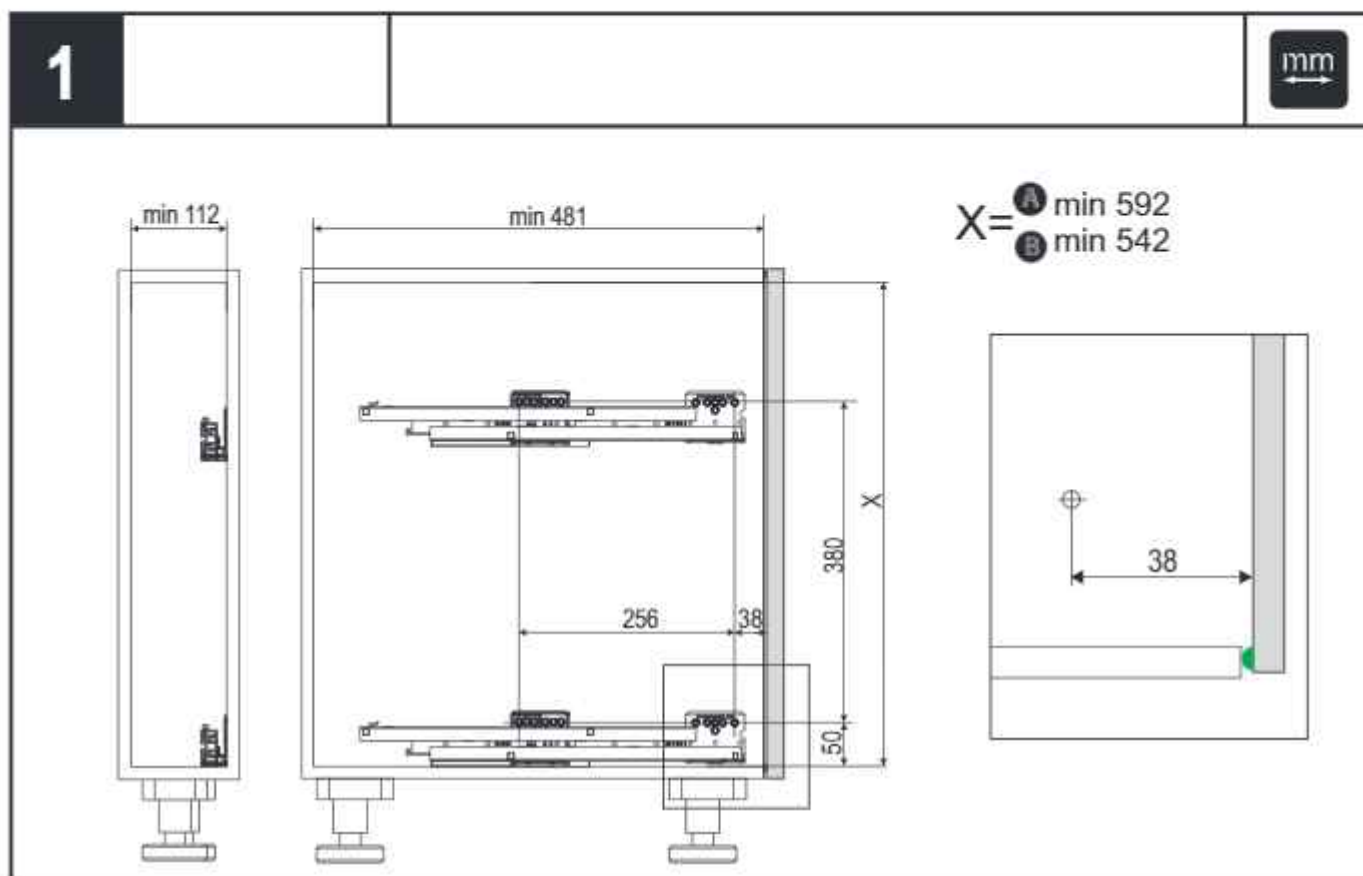



3		mm ↑↓

4		mm ↑↓

5		mm ↑↓



<http://support.kesseboehmer.de/15er>

Justieranleitung

Handtuchhalterauszug
Backblech- und Tablettauszug

Adjusting Instructions

Towelholder pull-out
Tray and baking tray pull-out

Kesseböhmer XP

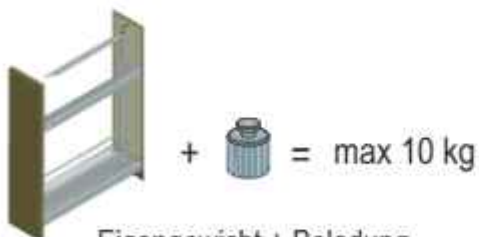
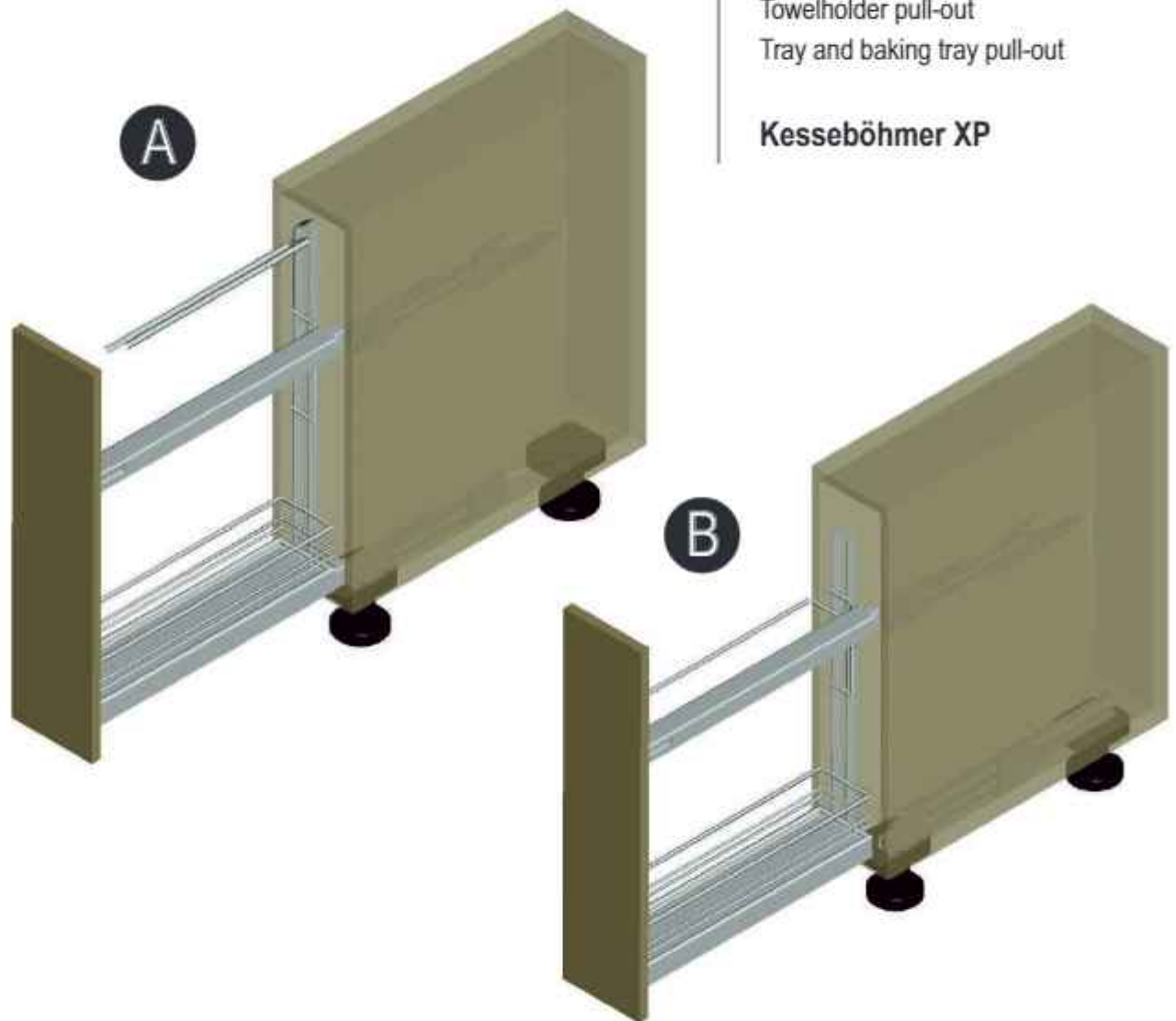

Eigengewicht + Beladung
Empty weight + Load

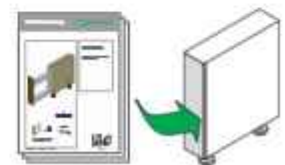

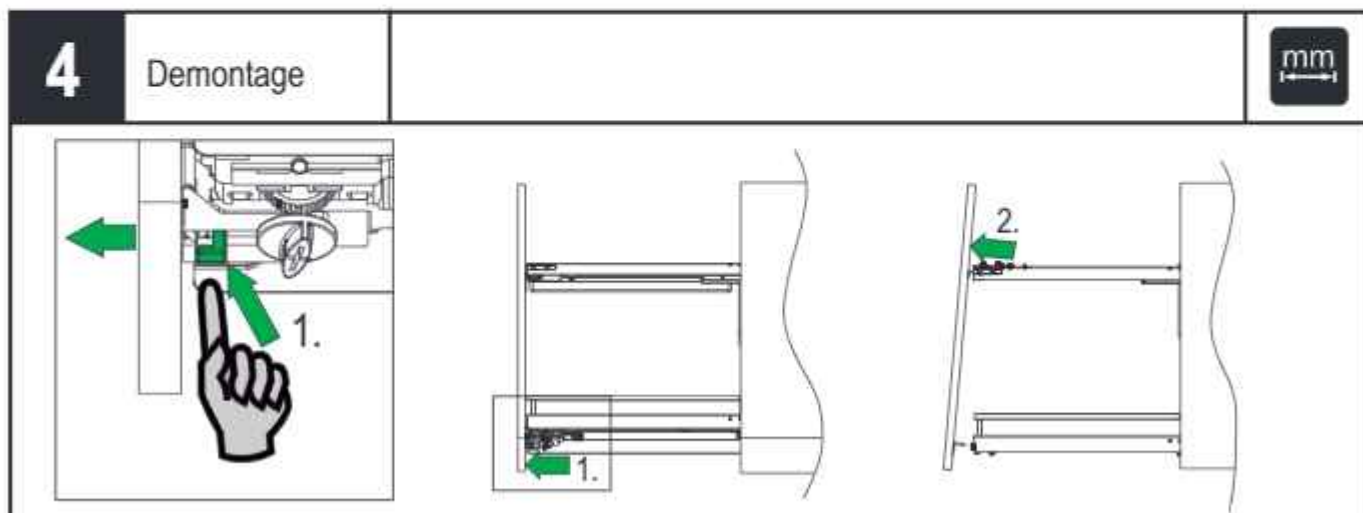
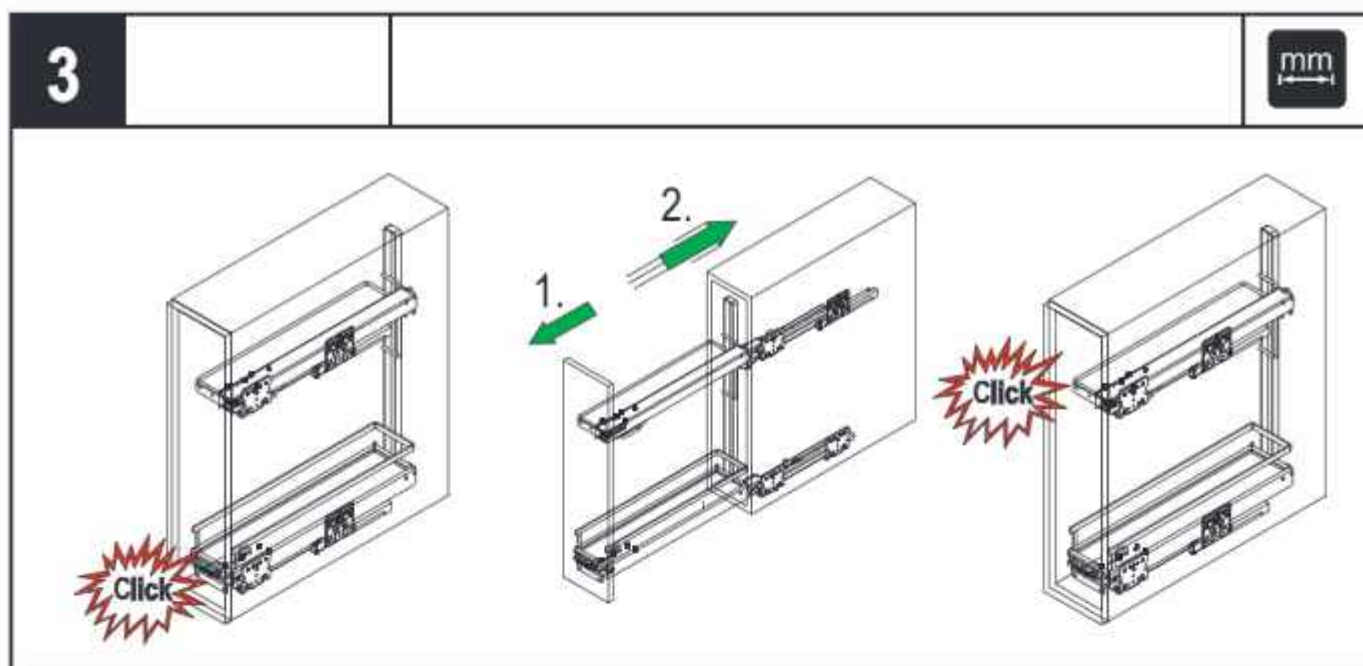
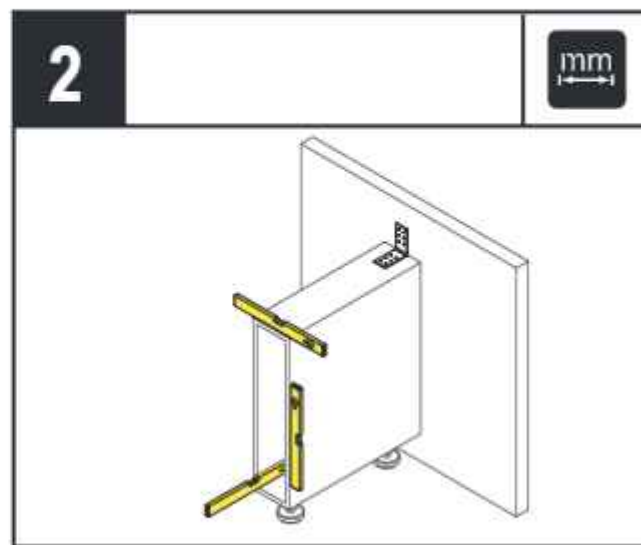
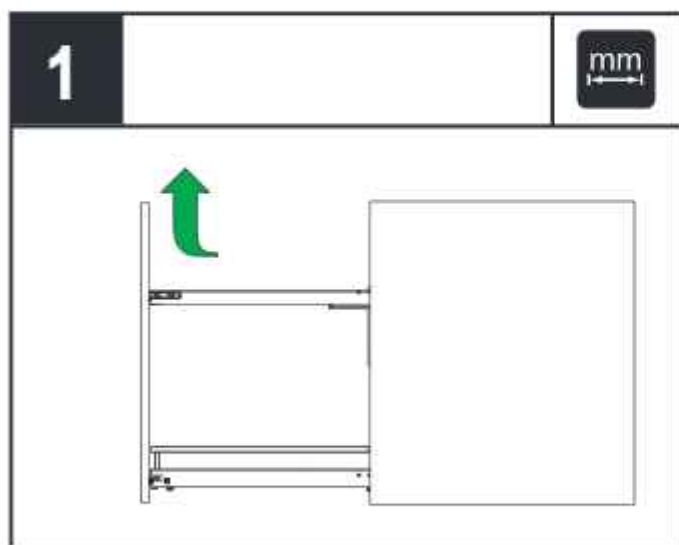

5

mm

